

4. Chose holding current – 100% or 70% of maximum current per phase for each axis and set SW3: On – 100% and Off – 70%.
5. Make wiring according to the section 4 “Assembly and connection”.
6. Check wiring once again and turn on the power supply.
7. To control the stepper motor set the required sequence of logic signals “STEP” (PUL+/PUL-), “DIR” (DIR+/DIR-) and “EN” (EN+/EN-) according to the scheme – image 3. One step (or microstep) executes as the front edge of the voltage pulse on the “PUL” input. Direction switches by changing voltage level on the “DIR” input. The motor windings release as the front edge of the high voltage level on the “EN” input.

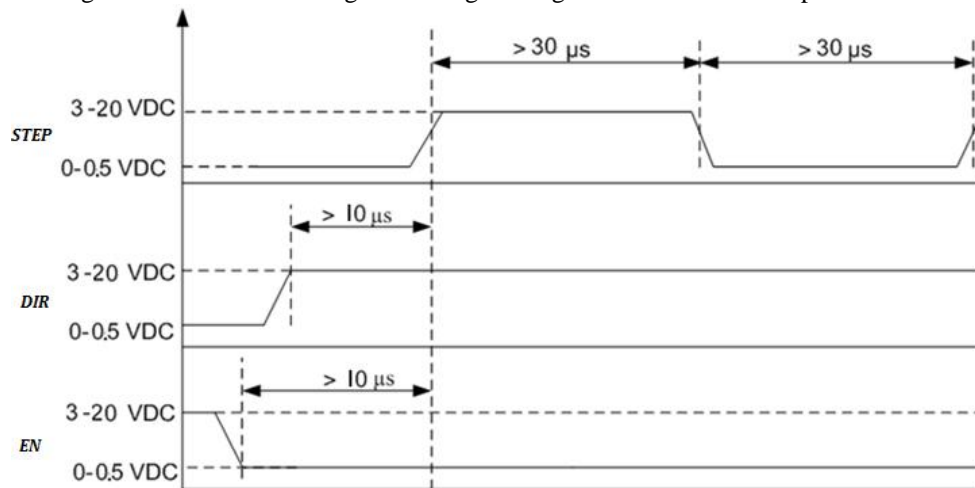

Img. 3 – STEP, DIR, EN signals

6. Delivery in complete sets

Three axis stepper motor driver SMD-303	1 pcs
Manual SMD.303.000	1 pcs

7. Warranty

Any repair or modifications are performed by the manufacturer or authorized company.

The manufacturer guarantees the failure-free operation of the controller for 12 months since date of sale when the operation conditions are satisfied – section 2.

The manufacturer sales department address:

Smart Motor Devices OÜ,
 Tallinn Science Park Tehnopol, Mäealuse st. 4,
 Tallinn 12618, Estonia,
 Phone: +372 6559914
 e-mail: mail@stepmotor.biz
 url: //www.stepmotor.biz



SMART MOTOR DEVICES

<http://www.stepmotor.biz>

THREE-AXIS STEP MOTOR DRIVER SMD-303

Manual

SMD.303.000

2013

1. Product designation

Three-axis step motor driver SMD-303 is an electronic device designed to operate contemporaneously with three 2 or 4-phase stepper motor with maximum current per phase up to 2.8Amp.

2. Technical characteristic

The SMD-303 driver receives logic signals “Step” (PUL+/PUL-), “Direction” (DIR+/DIR-) and “Enable” (EN+/EN-) and converts them into motor commutation. One step (or microstep) executes as the front edge of the voltage pulse on the “PUL” input. Rotation direction depends on the voltage level and switches by changing voltage level on the “DIR” input. The motor can be urgent stopped by the active signal on the “EN” input.

Maximum phase current and microstepping mode are set by switches at the driver frame.

Maximum output current per phase, Amp	2.8
Minimum output current per phase, Amp	0.5
Microstepping modes	1; 1/2; 1/8; 1/16
Voltage input, VDC	10 – 30
High voltage level of input signal, VDC	3...20
Low voltage level of input signal, VDC	0...0.8
Internal input resistance of control signals, kOhm	1
Minimum “Step” pulse length, μ s	30
Direction setting time, μ s	10
Maximum overall dimensions, mm	180x96x30

Environmental conditions:

Ambient Temperature: 0...+40°C
 Humidity: 90% RH
 Condensation and freezing: none
 Pressure: 650...800 mm of mercury

Table 1

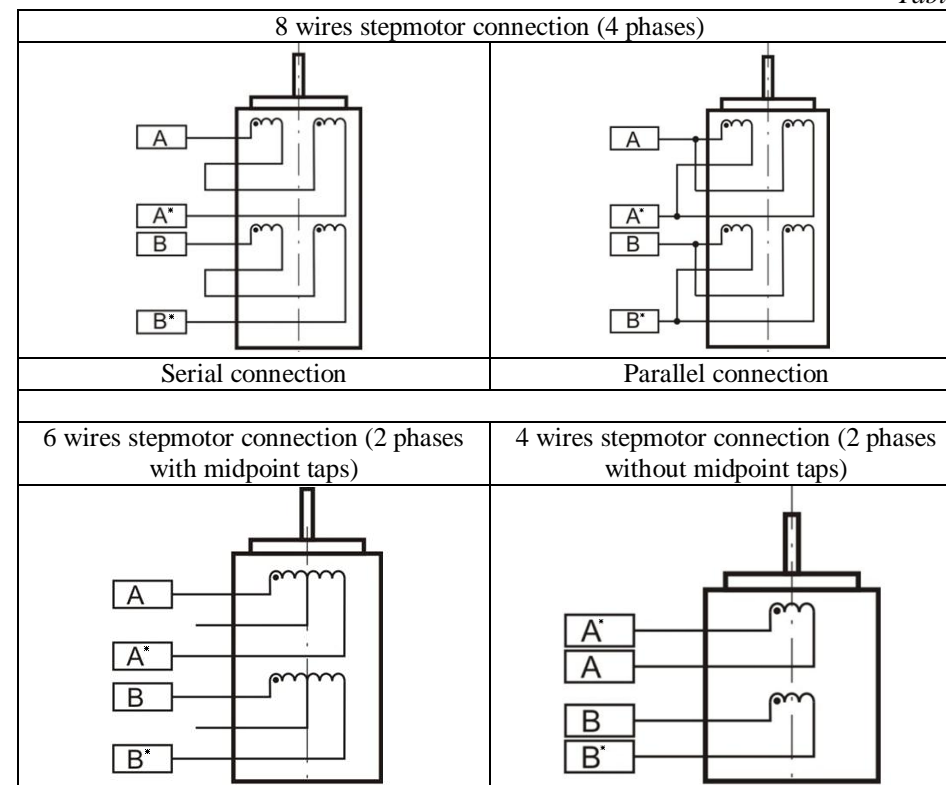

5. Before starting

1. Make sure the power supply is turned off.
2. Chose suitable microstepping mode for each axis and set microswitches SW1 and SW2 according to table 2.

Table 2

	1	1/2	1/8	1/16
SW1	ON	ON	OFF	OFF
SW2	ON	OFF	OFF	ON
Steps number per revolution (for 1.8° motor)	200	400	1600	3200

3. Chose suitable for the motor maximum current per phase for each axis and set microswitches SW4, SW5 according to the table 3. The output current should be set according the motor’s description. Low current leads to weak point of the motor, high current leads to the motor heating and can damage the motor.

Table 3

Current, Amp	0.5	1.2	2.0	2.8
SW4	OFF	ON	OFF	ON
SW5	OFF	OFF	ON	ON

4. Assembly and connection

Please, learn this manual carefully before connection and assembly.

Please, wire just when power is off. Do not attempt to change wiring while the power is ON.

Please provide a reliable contact in connection terminals. During wiring, please, observe the polarity and wire management.

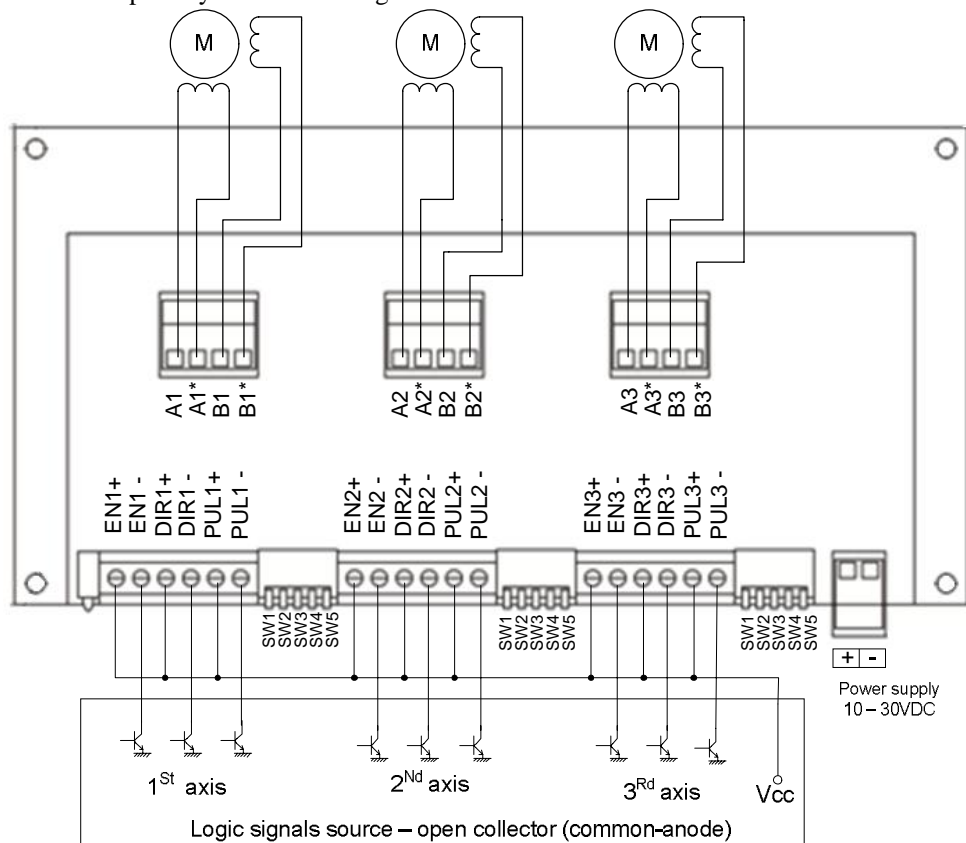

Img. 2. Connection scheme example

Assembly and connection order

Connect SMD-303 driver with stepper motors, signal sources and electric DC power supplier to scheme shown on image 2.

The SMD-303 driver provides contemporaneous operation with three 2 or 4-phase stepper motors, 4, 6 or 8 wires. Connect step motor wires to A, A*, B, B* terminals of SMD-303 axis according one of the above schemes shown in table 1.

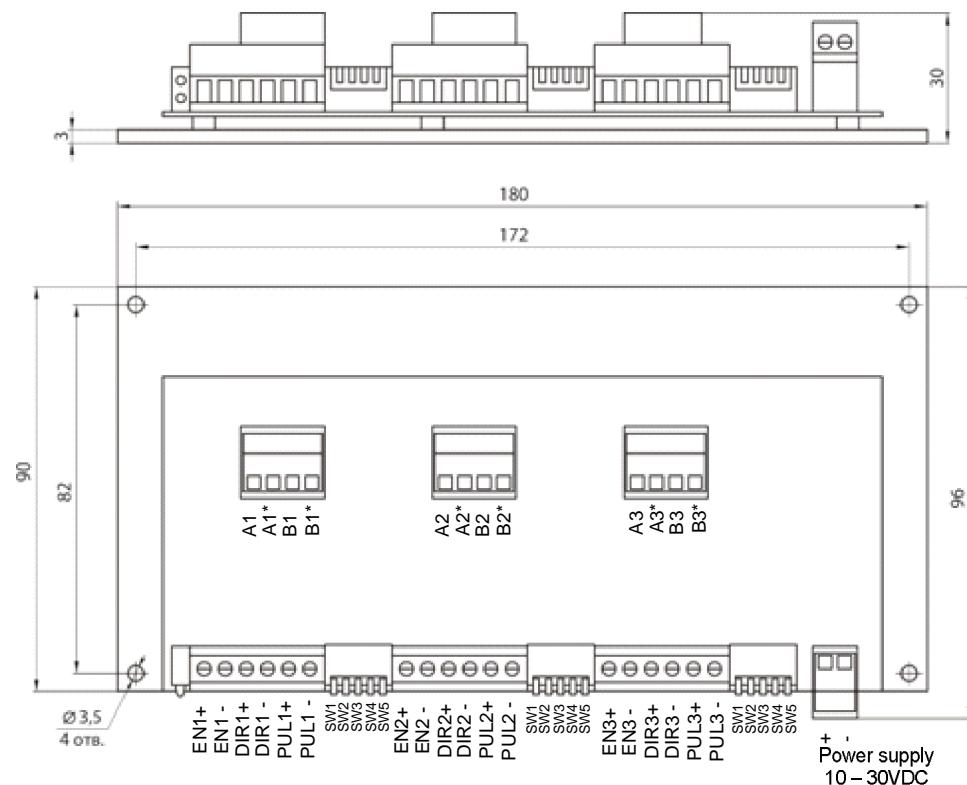

Img. 1. Dimensions

3. Construction

SMD-303 is designed as a circuit plate with electronics elements. Besides electronic components, there are indicating and control elements, connection terminals and connectors on a board:

- terminal screws for power supply, stepper motor windings and control circuit connection;
- LED for indication of the driver status: at power both LED indicators turn on, after 1 second red color LED indicator turns off; green color LED indicates normal work status; when the driver is overheated it turns off and red color LED indicator turns on, to reset this state it is necessary to turn off power supply;
- switches SW1, SW2 – to set the microstepping mode – separate for each axis;
- switches SW4, SW5 – to set the maximum output current per phase – separate for each axis;
- switch SW3 – to set full or reduced holding current.